

Pegler Valve

Gunmetal lockshield draincock type A to BS 2879/2, male taper thread to BS 21

833 GMLS Draincock



General Information

Key Features

- WRAS approved

Size	Pattern No.	Pack 1 Qty	Pack 2 Qty	Code	Barcode	Price (£) each ex VAT	Discontinued	Date Discontinued
1/2"	833GM LS	20	0	542037	5013866017322	£36.98		
3/4"	833GM LS	1	10	542038	5022050560988	Disc(Out of Stock)	Discontinued	03/07/2021
1"	833GM LS	1	5	542039	5022050561268	Disc(Stock available)	Discontinued	03/07/2021

833 GMLS Draincock

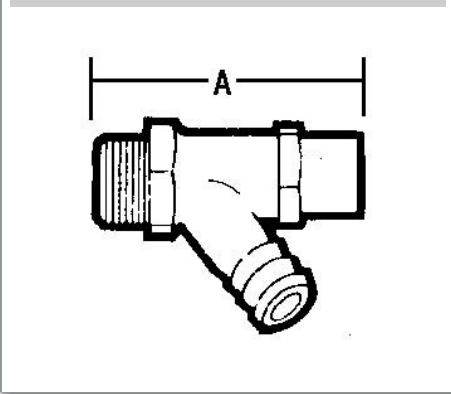

Dimensions

Code	Description	A	B	Kg
542037	1/2" 833GMLS GUNMETAL TYPE A DRAINCOCK LS	59	0	0

Pegler Yorkshire reserve the right to change specifications

Pressure and Temperature

Description	Minimum Operating Pressure (bar)	Maximum Cold Working Pressure (bar)	Maximum Hot Working Pressure (bar)
833 GMLS Drain cock	No Minimum Operating Pressure	20.0 bar at temperatures up to 120oC	Not Suitable for Maximum Hot Working Pressure

Care and Maintenance

Care

No regular aesthetic care is required for this product

Maintenance

No regular maintenance is required for this product.

For any further help please contact the Service Support Team on: 0800 1560050.

Materials

Component	Material
Body	Gunmetal
Headwork	Brass
Spindle	Brass
Washer	EPDM
Spindle 'O' ring	EPDM
Cap 'O' ring	EPDM

Component Material

LS cover Brass

Technical Suitability

Steam Water Oil Air Gas Inert Gas Combustible† Gas Corrosive†† Gas Oxygen
no yes yes no no no no no

Pegler Yorkshire reserve the right to change specifications

Gas application guide

Class 1. INERT Air, argon, carbon dioxide, helium, nitrogen

Class 2. COMBUSTIBLE Hydrogen, methane, natural gas, town gas

Class 3. CORROSIVE Chlorine, sulphur dioxide Class 4. OXYGEN

Class 1. INERT Air, argon, carbon dioxide, helium, nitrogen

† Valves are suitable for British Gas Applications Family Gases 1, 2 and 3.

†† Suitable in applications where moisture is completely absent.

833 GMLS Draincock

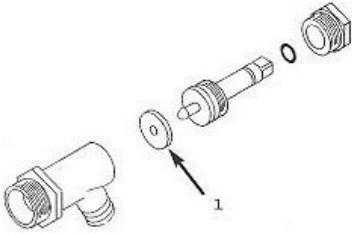

Spare Key	Description	Code	Barcode	Date From	Date To	Price (£) ex VAT
1						
1	VW25 VALVE WASHER	817100	5013866058516	01/01/1900	To Current	£1.31