

# Pegler Valve

PB500MF T Chromium plated brass ball valve male x female tee handle

PB500MF T Ball valve



## General Information

Size	Pattern No.	Pack 1 Qty	Pack 2 Qty	Code	Barcode	Price (£) each ex VAT
3/8"	PB500MF T	10	80	<a href="#">242160</a>	5022050168177	£14.76
1/2"	PB500MF T	10	80	<a href="#">242161</a>	5022050168412	£16.55
3/4"	PB500MF T	10	40	<a href="#">242162</a>	5022050168597	£24.80
1"	PB500MF T	5	30	<a href="#">242163</a>	5022050168832	£38.43

PB500MF T Ball valve

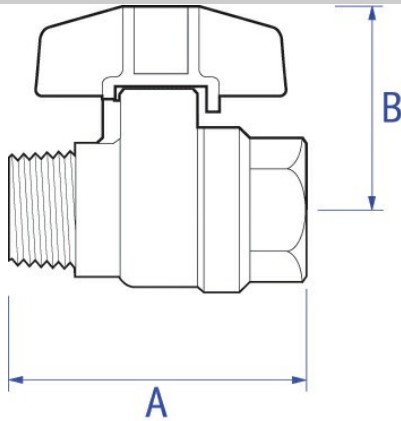

## Dimensions

Code	Description	A	B
242160	3/8" PB500MF T	53	37
242161	1/2" PB500MF T	57	40
242162	3/4" PB500MF T	69	51
242163	1" PB500MF T	81	55

Pegler Yorkshire reserve the right to change specifications

## Pressure and Temperature

Description	Minimum Operating Pressure (bar)	Maximum Cold Working Pressure (bar)	Maximum Hot Working Pressure (bar)
PB500MF T Ball Valve	No Minimum Operating Pressure	25.0 bar at temperatures up to 100oC	16.5 bar at temperatures up to 150oC

## Care and Maintenance

### Care

No regular aesthetic care is required for this product

### Maintenance

A regular maintenance program is the most efficient method of ensuring longer term operational efficiency of the selected valve. Such a program would need to include a risk assessment and a planned procedure of how the maintenance will be carried out. The possibility of operational limits being exceeded and the potential hazards ensuring must be considered as part of this assessment. This should be implemented to include visual checks on the valve's condition and any development of unforeseen conditions, which could lead to failure. The correct fitting tools and equipment should be used for valve maintenance work. Separate means of draining the pipe work must be provided when carrying out any maintenance to valves. Where there may be any system debris this could be collected and /or filtered by installation of the appropriate protective device.

For further help please contact your local engineer.

If your product is under warranty please contact the Service Support Team on: 0800 1560050

## Regulations

#### **Regulations**

#### **THE PRESSURE EQUIPMENT DIRECTIVE 97/23/EC and CE MARKING**

The Pressure Equipment Regulations 1999 (SI 1999/2001) have now been introduced into United Kingdom law.

Valves with a maximum allowable pressure greater than 0.5 bar are covered by these new Regulations. Valves are categorised according to their maximum working pressure, size and rising level of hazard. The level of hazard varies according to the fluid being carried. Fluids are classified as Group 1, dangerous fluids or Group 2, all other fluids including steam. The Categories designated are SEP (sound engineering practice). Valves up to and including 25mm (1") are designated SEP regardless of the fluid group. Those identified as having increased hazard are Categorised as, I, II, III or IV. All valves designated as SEP do not bear the CE mark nor require a Declaration of Conformity. Categories I, II, III or IV carry the CE mark and require a Declaration of Conformity. Valves classified from the piping chart would not be included in Category IV.