

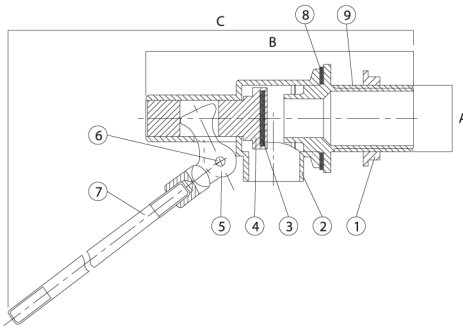

PEX-806

brass MOH float valve

(if required with orange PP ball float please order as PEX-836)



- solid brass one piece construction
- brass back nut
- brass piston

maximum pressure conditions:
14 bar - temp up to 160°C

available sizes as per the
'standard packing details' table

standard packing details						
size	1/2"	3/4"	1"HH	1.1/4"	1.1/2"	2"
item weight (kg)	0.264	0.304	0.629	1.43	1.52	1.62
inner box contains	75	50	20	16	16	16
box weight (kg)	20.5	15.5	13.0	24.0	25.0	26.0
full pallet contains	3375	2250	1080	384	384	384
pallet weight (kg)	937.5	712.5	717.0	591.0	615.0	639.0
dimension A	1/2"	3/4"	1"	1.1/4"	1.1/2"	2"
dimension B mm	78	79	92	167	167	170
dimension C mm	255	305	360	470	515	515
flow rate at 1bar (m ³ /hr)	0.47	0.73	1.63	3.9	4.2	4.6
hole in seat diameter mm	6.0	7.5	11.5	25	25	25

material specification		
key	component	material
1	flange nut	brass
2	body	brass
3	washer	EDPM
4	piston	brass
5	arm sleeve	brass
6	pin	brass
7	arm	brass
8	washer *	fibre
9	tail	brass
* on sizes larger than 1"		

recommended float sizes		
valve size	ball size	item code (valve & float)
3/8"	4.1/2"	PEX - 836 - 3/8 - 4.1/2
1/2"	4.1/2"	PEX - 836 - 1/2 - 4.1/2
3/4"	5"	PEX - 836 - 3/4 - 5
1"HH	6"	PEX - 836 - 1 - 6
1.1/4"	8"	PEX - 836 - 1.1/4 - 8
1.1/2"	10"	PEX - 836 - 1.1/2 - 10
2"	10"	PEX - 836 - 2 - 10