

STUART

Submersible Pumps

Designed to pump solids up to 5 mm and can be used in either automatic or manual modes. Complete with integral float switch, the Supersub 250VA is ideal for the transference of non foul water and suitable for both clean and grey water.

The pump is compact in design and easy to install.



Features

- Submersible pump
- Flow rates up to 250 litres per minute and heads up to 8.5 metres
- Suitable for transference of non foul water including solids up to 5 mm
- Automatic and manual operation modes
- Continuously rated
- 1 year guarantee

Application

- The Supersub 150VA and 250VA are both ideal for the transfer of rain water, dirty or waste water where automatic control is required in a confined space such as cellar drainage

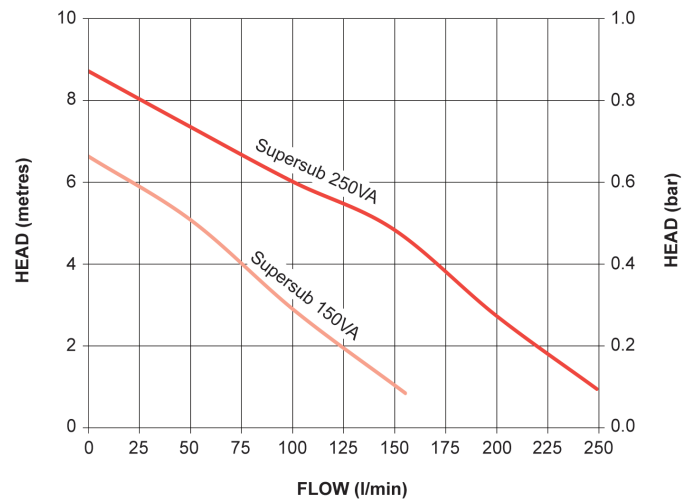

Pump Model		Supersub 150VA 50 Hz 46538	Supersub 250VA 50 Hz 46539
General	Guarantee	1 years	
	Approvals	CE	
Features	Pump type	Submersible	
	Pump control	Float switch	
	Carry handle	✓	✓
	Manual mode	✓	✓
	Automatic float switch	✓	✓
	Noise	35 dB(A)	35 dB(A)
Materials	Pump body	Polypropylene	
	Impeller	Plastic	
	Pump mechanical seal	Double lip	
Performance	Maximum head (closed valve)	6.5 metres	8.5 metres
	Performance @ 50 l/min	5.0 metres	7.5 metres
	Performance @ 100 l/min	3.5 metres	6.5 metres
	Maximum flow	150 l/min	250 l/min
	Minimum immersion depth	Fully submerged	
	Maximum immersion depth	7 metres	
	Suction to remaining depth - manual mode	3 - 6 mm	
	Suction to remaining depth - automatic mode	75 mm	
	Maximum suspended particle size	5 mm	
	Min / Max water temperature**	Min 4 °C / Max 35 °C	
Connections	Pump connections - outlet	G 1½ female	
	Hose connector	G 1½ male x G 1½ female x 25 or 32 mm bore hose	
Motor	Type	Induction (thermal trip / auto reset)	
	Duty rating	Continuous (S1)	
Electrical	Power supply / phase / frequency	230 V a.c. / 1 / 50 Hz	
	Power consumption	290 Watts	523 Watts
	Current (full load)	1.3 Amps	2.4 Amps
	Fuse rating	5 Amps	
	Power cable (pre-wired)	10 metres	
Physical	Enclosure protection	IPX8	
	Width	260 mm	
	Depth	158 mm	
	Height (excluding hoses)	320 mm	
	Weight (including fittings)	4.2 Kg	5.0 Kg
Optional accessories	Lay flat hose 32 mm x 5 m	Pt No 19965	
	Lay flat hose 32 mm x 10 m	Pt No 19966	
	Lay flat hose 32 mm x 15 m*	Pt No 20363	

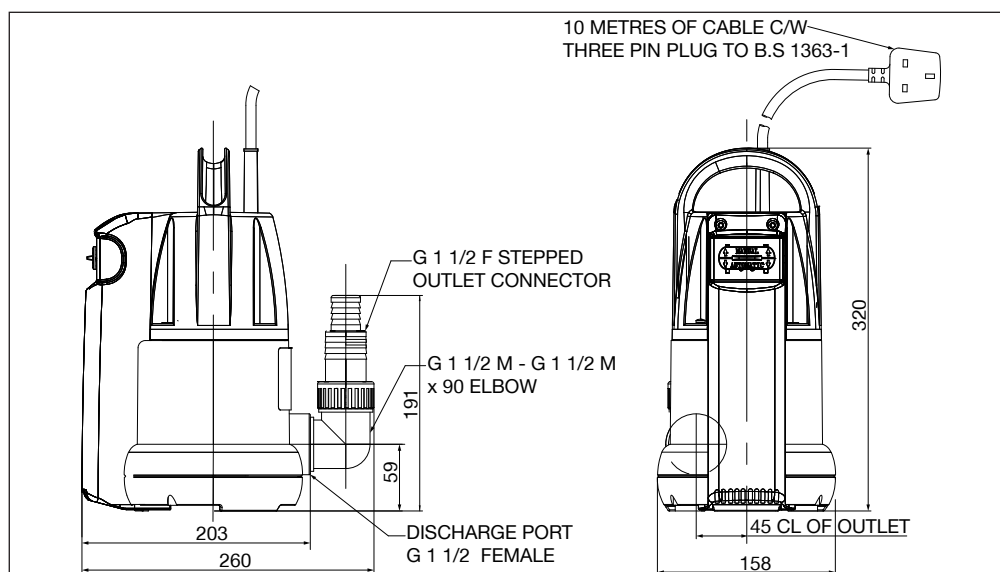

* This hose is suitable for the Supersub 250VA model only.

Stuart Turner Limited reserves the right to amend specifications without notice.